



COMMERCIAL

# commercial 3100

The **3100 Commercial Series** is our certified windload rated, rolling sheet door that meets specified wind loads required by even the most stringent building codes. Independent laboratory testing proves the strength and durability of the 3100 series. The quick installation and smooth operation, compared to other doors, further demonstrates how user friendly this door is.



**Maximum**  
20' x 18'

Available in sizes up to 20' x 18' and in more than 30 colors, customized for your application.



**Medium-Duty**  
Application

Ideal for medium-duty locations, such as warehouses, commercial buildings, and freight terminals.



**Wind Load**  
Rated

Superior construction and innovative design make this door able to withstand heavy winds and extreme weather.



**Quality**  
Guaranteed

One-year door warranty. For paint, 35-year no-fade, 40-year film integrity.



## Features

- » **Pre-Lubricated Springs**  
During production, springs are factory lubricated and enclosed in a tube to protect them from the environmental elements.
- » **Dead Axle & Barrel Assembly**  
An enclosed spiral barrel houses the dead axle assembly and offers durability and smoother operation as weight is distributed throughout the barrel.
- » **26-Gauge Corrugated Door Curtain**  
Manufactured from galvanized grade 80 steel and coated with super durable polyester paint in more than 30 color options.
- » **Insulated Version Available**  
Side and top draft stops included.

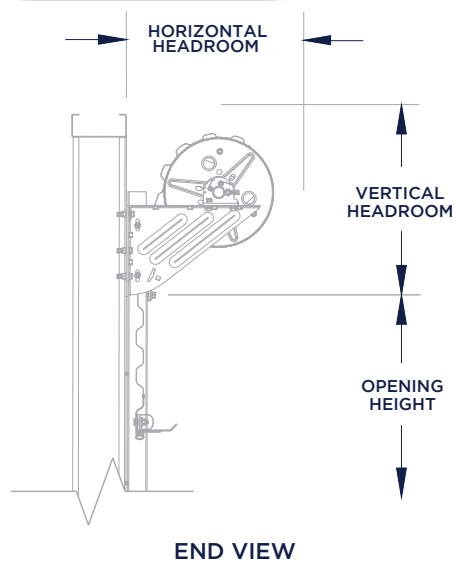

## IMPORTANT NOTES:

- Dimensions are referenced from edge of opening.
- Tensioner end and drive end can be installed at either end of door assembly.
- FOR CRITICAL FITS DUE TO REDUCED AVAILABLE HEADROOM or SIDEROOM CLEARANCES, CONSULT FACTORY.

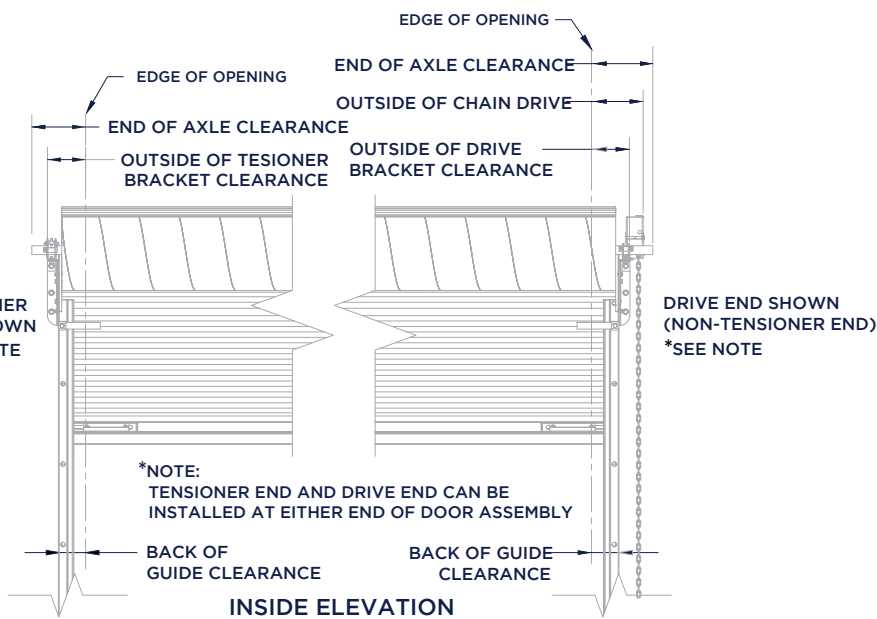

Universal mount 4" deep 12-gauge galvanized steel wind bar guides require no pre-installation modifications for steel, concrete or filled masonry block applications.

## SPECIFICATIONS

### Guide Details

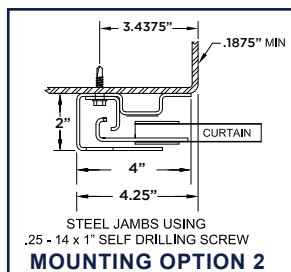
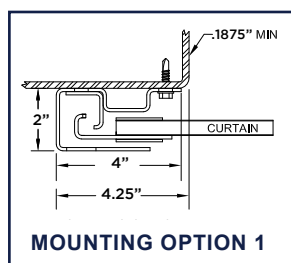
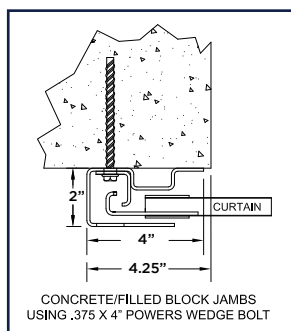

### Head Room Requirements

Opening Height	Vertical Headroom	Horizontal Headroom
Thru 8'0"	20"	20"
Over 8'0" thru 10'0"	21"	21"
Over 10'0" thru 14'0"	21.5"	21"
Over 14'0" thru 16'0"	22"	22"
Over 16'0" thru 18'0"	22"	22"
Over 18'0" thru 20'0"	22"	22"

### Side Room Requirements

Operation	Guide	Outside of Bracket Tensioner End	Outside of Hand Chain Drive	Outside of Bracket Drive End	Each End of Axle
Push Up	4.25"	6.25"	N/A	6.25"	9"
Reduced Drive Chain	4.25"	6.25"	8.75"	6.75"	9"
Electric	4.25"	6.25"	N/A	7.75"	9"

### HIGHLIGHTS:

- B** Barrel: 12"
  - G** Guide: 4", 12-gauge
  - 5:7:1 reduced-drive chain hoist offers smoother operation on doors over 10' tall.
- Visit [rollupdoorsdirect.com](http://rollupdoorsdirect.com) for technical drawings, color options and more.